

Type number key

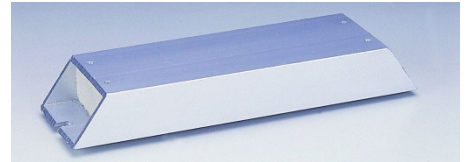
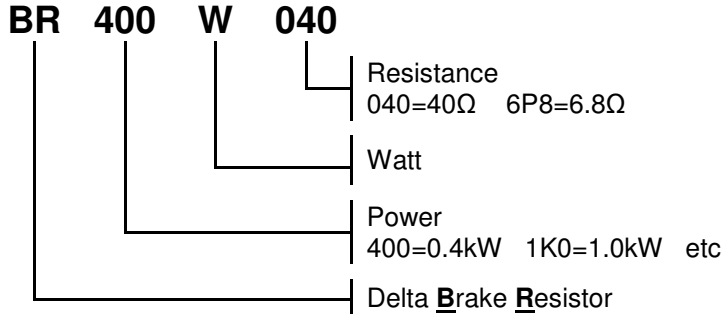

Overview: Power, Resistance, Dimensions

Resistor type	Power (kW)	Resistance (Ω)	L1 (mm)	L2 (mm)	H (mm)	D (mm)	W (mm)	Wire length (mm)	Weight (kg)	Drawing
BR080W200	0.08	200	140	125	20	5.3	40	150	0.16	2
BR080W750		750								
BR200W091	0.2	91	165	150	30	5.3	60	200	?	1
BR200W360		360								
BR200W150		150								
BR200W250		250								
BR300W025	0.3	25	215	200	30	5.3	60	150	0.75	2
BR300W070		70								
BR300W100		100								
BR300W110		110								
BR300W250		250								
BR300W400		400								
BR400W040	0.4	40	265	250	30	5.3	60	150	0.93	2
BR400W150		150								
BR500W030	0.5	30	335	320	30	5.3	60	N/A	1.1	3
BR500W100		100								
BR1K0W020	1.0	20	400	385	50	5.3	100	N/A	2.8	4
BR1K0W075		075								
BR1K0W4P3		4.3								
BR1K0W5P1		5.1								
BR1K0W016		16								
BR1K0W050	50									
BR1K2W3P9	1.2	3.9	See drawing #6							6
BR1K2W6P8		6.8								
BR1K2W008		8								
BR1K2W015		15								
BR1K5W3P3	1.5	3.3								
BR1K5W005		5								
BR1K5W012		12								
BR1K5W013		13								
BR1K5W040		40								
BR1K5W043		43								

Brake resistor type vs. Drive type (Voltage&Power)

For use in the different drives, either with built-in brake chopper or additional option brake unit, please refer to the related user manuals.

Dimensional drawings

#1

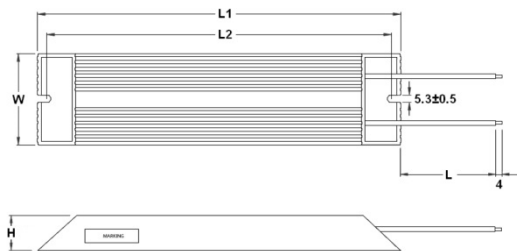

#2

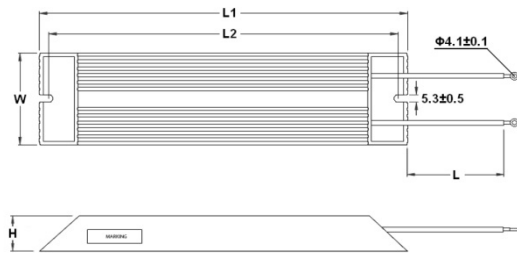

#3

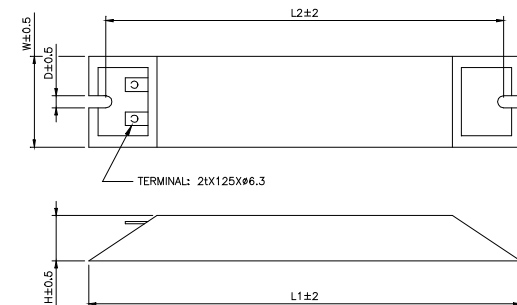

#4

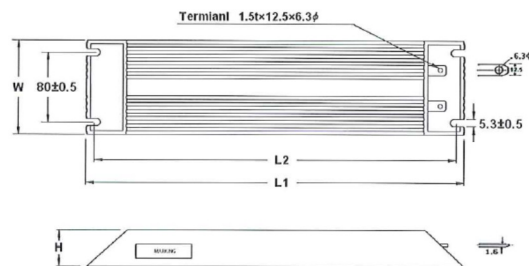

#5

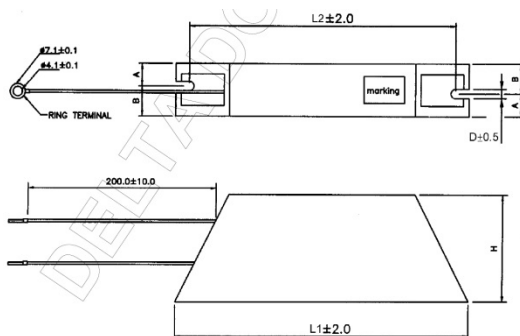

#6

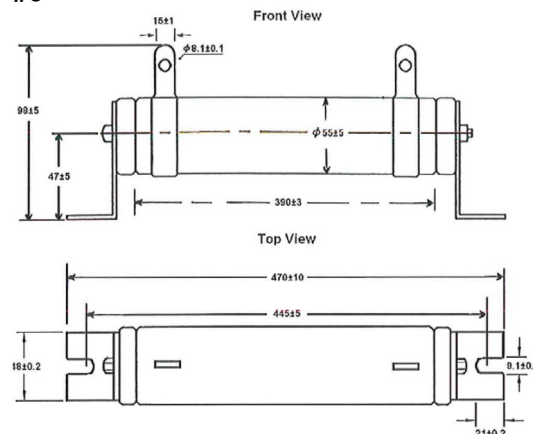

Specifications

Test	Test conditions	Specification
Operating temperature		-55 ~ 250°C >200°C: use forced cooling with airspeed 3~10m/s -55 ~ 600°C for resistors acc. drawing #6 >350°C : use forced cooling with airspeed 3~10m/s
Tolerance	at 25°C	±5%
Temperature coefficient		±260ppm/°C
Housing material		Oxidized aluminium Ceramic coating for resistors acc. to drawing #6
Isolation resistance	between terminals (terminal wire) and housing or mounting bracket	100MΩ @500VDC 1min
Dielectric strength	between terminals (terminal wire) and housing or mounting bracket	1500VAC 1min
Overload	Cycle 10s on ~ 90s off	10x rated power
Lead pull strength		2.5kg 10s Not applicable when resistor has no leads acc. to drawing
Vibration	10~55~10Hz sweep in 1min Amplitude 0.75mm	2hrs per direction